

FSR 700/650 240 LWB



WEIGHT RATINGS*

GVM 12,000 kg / 14,000 kg
GCM 16,000 kg

ENGINE

POWER 177 kW @ 2,400 rpm
TORQUE 765 Nm @ 1,600 rpm

TRANSMISSION

6 speed manual transmission (MT)
 6 speed automatic transmission (AMT)

* Refer to back page for detailed weight rating information

INTELLIGENT SAFETY		
ACTIVE SAFETY ADVANCED DRIVER ASSISTANCE SYSTEMS (ADAS)	Advanced Emergency Braking	(AEB)
	Forward Collision Warning	(FCW)
	Distance Warning System	(DWS)
	Lane Departure Warning	(LDW)
	Electronic Stability Control	(ESC)
	Anti Skid Regulator	(ASR)
	Anti Lock Braking System	(ABS)
	Hill Start Aid	(HSA)
	Electronic Braking System	(EBS)
	Cab Tilt Warning	(CTW)
PASSIVE SAFETY CABIN OCCUPANT SAFETY SYSTEMS (COSS)	Driver & front passenger airbags	
	Driver & front left hand passenger seatbelt pretensioners	
	ECE-R29 cab with side anti-intrusion beams	

ISUZU WARRANTY COVER	
WARRANTY	5 year / 300,000 km Warranty#

ENGINE	
DESCRIPTION	Isuzu N-4HK1-TCH
TYPE	4 cylinder 16 valve SOHC
DISPLACEMENT	5,193 cc
COMPRESSION RATIO	16.5:1
BORE X STROKE	115 mm x 125 mm
POWER	177 kW (240PS) @ 2,400 RPM (DIN NET)
TORQUE	765 Nm @ 1,600 RPM (DIN NET)
INDUCTION	Low pressure turbocharger and high pressure Variable Geometry System (VGS) turbocharger sequentially operated and with with air-to air intercooler.
FUEL INJECTION	Direct injection high pressure common rail system. Exhaust pipe fuel injection for DPD regeneration
EMISSION CONTROL	Cooled EGR with exhaust Diesel Particulate Diffuser (DPD) . ADR 80/03 (Japan PNLT) compliant.

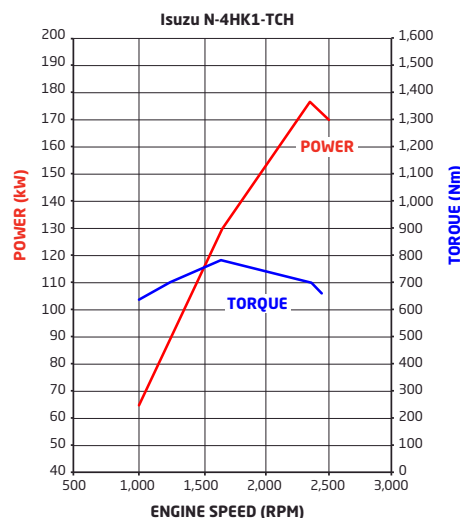

TRANSMISSION							
MT	CLUTCH	Type: Single plate with air assisted hydraulic control					
		Clutch plate diameter: 352 mm					
		Clutch lining area: 1,164 cm ²					
	GEARBOX	Description: Isuzu MZW-6P					
Type: 6 speed with synchromesh on gears 2-6							
Ratios:							
1st		2nd	3rd	4th	5th	6th	Rev
	6.615	4.095	2.358	1.531	1.000	0.722	6.615
Power Take Off facility: PTO provision on LHS of transmission case							
Other features: Air assisted shift, full pressure oil lubrication							
AMT	Description: Isuzu MZW-6P						
	Type: 6 speed with both fully automatic and clutchless manual operation modes						
	Ratios:						
	1st	2nd	3rd	4th	5th	6th	Rev
		6.615	4.095	2.358	1.531	1.000	0.722
Power Take Off facility: PTO provision on LHS of transmission case. PTO drive from mainshaft gear							
Other features: Integrated automated wet clutch and torque convertor (TC) with lock up							

AXLES	
FRONT	Description: Isuzu F050
	Type: Reverse Elliot I-beam
	Capacity: 5,000 kg
REAR	Description: Isuzu R090
	Type: Single drive
	Capacity: 9,000 kg
	Ratio: 5.571

SUSPENSION	
FRONT	Type: Single stage alloy steel taper-leaf springs
	Other features: Double acting hydraulic shock absorbers. Stabiliser bar.
REAR	Type: Multi-leaf main spring, multi leaf helper spring

BRAKES	
TYPE	Full air dual circuit taper taper roller front and rear drum brakes
DIAMETER X WIDTH FRONT	370 x 150 mm
DIAMETER X WIDTH REAR	370 x 150 mm
PARK BRAKE	Spring park brake acting on all rear wheels
AUXILIARY BRAKE	Air controlled exhaust brake

STEERING	
TYPE	Power assisted recirculating ball
GEAR RATIO	16.1 - 18.8:1
TURNS LOCK TO LOCK	4.1
WHEEL LOCK ANGLE	44° (inside wheel) / 34° (outside wheel)

WHEELS & TYRES		
FRONT	Wheels:	19.5 x 6.75 eight stud ISO standard steel wheels
	Tyres:	265/70R19.5 140/138M
	Steer axle tyre rating	5,000 kg
REAR	Wheels:	19.5 x 6.75 eight stud ISO standard steel wheels
	Tyres:	265/70R19.5 140/138M
	Drive axle tyre rating:	9,440 kg
Spare: Spare wheel and tyre assembly supplied. Winch type carrier.		

CHASSIS FRAME	
TYPE	Cold rivetted ladder frame with parallel side rails.
MATERIAL	HT540A steel sidemembers
DIMENSIONS	Side rail (mm): 225 x 70 x 6.0 Rear frame width (mm): 840

FUEL TANK	
TYPE	Frame mounted steel fuel tank
CAPACITY	200L
FUEL CAP	Lockable

ELECTRICAL SYSTEM	
TYPE	24 volt
ALTERNATOR	90 amp
STARTER MOTOR	5.0 kW
BATTERY	2 x 115E41L (651 CCA) batteries connected in series
CAN BUS PROVISION	Underdash CAN system access plug for connection to a Fleet Management System (FMS) (not supplied)

CABIN GENERAL FEATURES	
ENGINE ACCESS	Manual cab tilt to 45° with torsion bar assistance
STEPS	Heavy duty anti slip steps
DOORS	90° opening internally reinforced front doors
MIRRORS	Heated & powered exterior main mirrors with flat glass and additional independantly adjustable convex "spot" mirrors
WIPERS	Two speed windscreen wipers with intermittent wipe mode
EXTERIOR LIGHTING	LED main beam & halogen high beam headlamp assembly with position lamp
	Roof mounted clearance lamps
	Front foglamps
AUDIBLE WARNING	Reverse alarm
GRILLE	Body coloured
FRONT BUMPER	Body coloured air dam type
SECURITY	Central locking with remote keyless entry & immobiliser

CABIN INTERIOR	
SEATING	Isri 6860/875 NTS air suspension driver's seat
	Front passenger adjustable bucket seat and front centre seat with folding seat back.
SEATBELTS	3-point lap sash seatbelts in all outboard seating positions. Driver seatbelt integrated with driver seat. Centre seat lap belts.
STEERING COLUMN	Tilt/telescopic adjustable
ENTRY ASSIST GRIPS	Door & roof pillar mounted
DOOR WINDOWS	Electric control
STORAGE	Overhead compartments
	Twin cup holders
	Centre console box & storage tray
	Front door pockets
POWER OUTLET	24V cigarette lighter
AIRCONDITIONING	Manual control
INTERIOR LIGHTING	Fluorescent lamp

AUDIO VISUAL UNIT	
SCREEN TYPE	6.2" LCD with capacitive touch
OPERATING SYSTEM	Android
RADIO	AM / FM
INTERNAL STORAGE CAPACITY	32GB
OTHER CAPABILITY	Bluetooth features. USB 3.0 socket. Provision for external camera inputs, navigation, reverse sensors, and tyre pressure monitoring.

DRIVER CONTROLS	
SAFETY SYSTEMS	AEB on/off, DWS on/off/sensitivity adjust, LDW on/off/sensitivity adjust, ESC on/off, HSA on/off/sensitivity adjust
ENGINE	Idle stop system on/off
	Idle speed control
	Cruise control
	DPD manual regeneration switch
TRANSMISSION (AMT ONLY)	Slow/fast gear engagement control, 1st gear start and normal/economy gear selection modes.
	Gear selection control with R-N-D and sequential shift positions
GENERAL CONTROLS	Headlamp on/off and levelling, windscreen wipers (2 speed and intermittent modes), washers, exhaust brake, turn signals

INSTRUMENTATION	
MULTI INFORMATION DISPLAY	AEB, FCW, DWS, LDW systems activation alerts
	CTW indicator
	Low engine oil level alert
	Vehicle systems status
	Low fuel level alert
	Fuel consumption information
	Service interval alerts
	Hourmeter
GENERAL INSTRUMENTATION	Adjustable vehicle speed warning
	Speedometer & tachometer
	Digital odometer with integrated dual tripmeters
	Engine coolant temperature, fuel level and air pressure guages

WEIGHTS (kg)							
MODELS	RATINGS*		LOADING LIMIT* (at ground)		CAB CHASSIS WEIGHT #		
	GVM	GCM	FRONT	REAR	FRONT	REAR	TOTAL
FSR 700/650 240 LWB	14,000 / 12,000	16,000**	5,000	8,200	2,460	1,380	3,840
FSR 700/650 240 AMT LWB	14,000 / 12,000	16,000**	5,000	8,200	2,480	1,390	3,870

*Vehicle ratings and front/rear weight limits are subject to government regulatory requirements and weight distribution analysis. Consult your Isuzu dealer to select the correct vehicle for your specific application. #Cab chassis only as supplied and including 10 litres of fuel.

** Max towed mass 3,500kg

DIMENSIONS (mm)													
MODELS	WB	OAL	FOH	ROH	EA	CE	RT	ORT	CH	FFA (unladen)	RFA (unladen)	RFH (unladen)	TURNING CIRCLE KERB TO KERB (m)
FSR 700 240 LWB	5,320	8,625	1,170	2,135	4,690	6,900	1,705	2,260	2,665	755	875	920	19.0

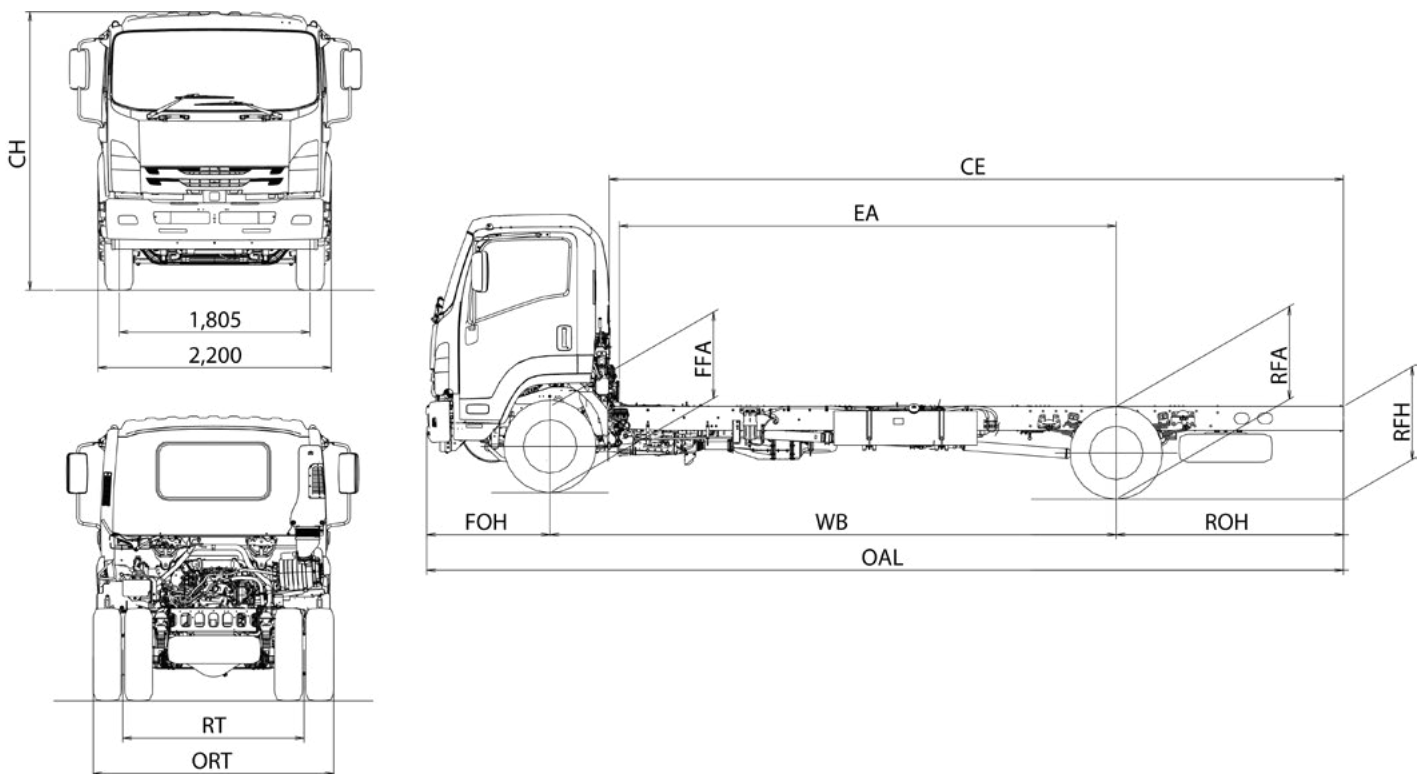

PERFORMANCE (calculated - typical paved road)				
		GEARED SPEED~ (top gear at peak power engine rpm)	LOW SPEED GRADEABILITY (lowest forward gear assuming no wheel slip)	ENGINE SPEED (top gear at 90 km/h)
FSR 700 240 LWB	at 14,000 kg GVM	95 km/h @ 2,400 rpm	43%	2,263 rpm
FSR 700 240 AMT LWB	at 14,000 kg GVM	95 km/h @ 2,400 rpm	53%	2,263 rpm
FSR 650 240 LWB	at 12,000 kg GVM	95 km/h @ 2,400 rpm	51%	2,263 rpm
FSR 650 240 AMT LWB	at 12,000 kg GVM	95 km/h @ 2,400 rpm	62%	2,263 rpm

* Maximum speed achievable depends on vehicle frontal area as well as other factors. Consult your Isuzu dealer for more detailed information.

ORDER CODES	
MODELS	CODES
FSR 700 240 LWB	FS2222
FSR 650 240 LWB	FS2722
FSR 700 240 AMT LWB	FS2322
FSR 650 240 AMT LWB	FS2822

#Total 5 Year Warranty, including Base Warranty (36 months / 150,000kms) and Additional Warranty (24 months / 150,000kms), cover is 60 months or 300,000kms, whichever comes first. To qualify for Additional Warranty, all scheduled servicing during the Base and Additional Warranty periods (ie. the total 60 months) must be performed by an authorised Isuzu service dealer from the date of delivery to the first customer. If scheduled servicing is performed by unauthorized service providers, only the Base Warranty will apply. Tipper bodies are excluded from Additional Warranty. These are covered by Base Warranty only.

The information in this spec sheet was correct at time of printing, but all measurements, specifications and equipment are subject to change without notice. Some equipment may have been changed and/or is available at extra cost. Isuzu New Zealand (INZ) may make changes at any time without notice, in prices, colours, materials, equipment and models. INZ makes all reasonable attempts to ensure the availability of all vehicles and equipment. The information in this spec sheet is general in nature. Your Isuzu dealer can confirm all measurements, specifications and vehicle / equipment availability upon request. To the extent permitted by the law, INZ is not liable to any person as result of reliance on the content of this spec sheet.