



# ISUZU

TRUCKS YOU CAN RELY ON

## SPECIFICATIONS



MODEL				

- Advanced Safety Features:**
- ✓ Advanced Emergency Brake System (AEBS) with distance warning
  - ✓ Electronic Vehicle Stability Control (EVSC)
  - ✓ Lane Departure Warning System (LDWS)

ENGINE			
Engine Model		Type	
Displacement		Compression Ratio	
Max Power (DIN Nett)			
Max Torque (DIN Nett)			
Emission Control System			
Fuel System			
Air Intake System			

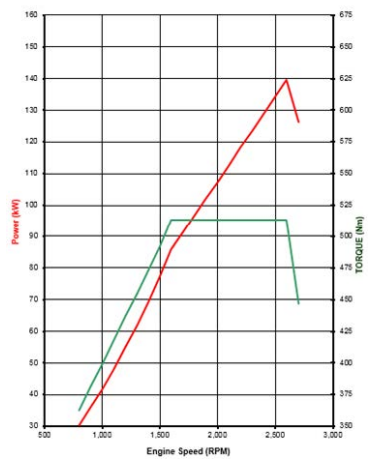

CLUTCH		PERFORMANCE	
			Speed Limit: <input type="text"/>

TRANSMISSION	

AXLES	

WHEELS AND TYRES	

CHASSIS			
Suspension	Chassis	Brakes	Electrical & Steering



# ISUZU

TRUCKS YOU CAN RELY ON

## SPECIFICATIONS

CAB AND INTERIOR		
Cab Exterior	Cab Interior	Instruments and Controls

WEIGHTS (KG)								
Model Codes	Models	Ratings*		Loading Limits (at ground)*		Chassis Cab Tare Mass**		
		GVM	GCM	Front	Rear	Front	Rear	Total

\* Vehicle ratings and front and rear mass limits are subject to regulatory requirements – Consult your dealer to select a specific vehicle to suit your requirements  
 \*\* Chassis cab as supplied from the factory including 10 litres of fuel

DIMENSIONS (mm) *Unladen condition								Turn Circle (m)

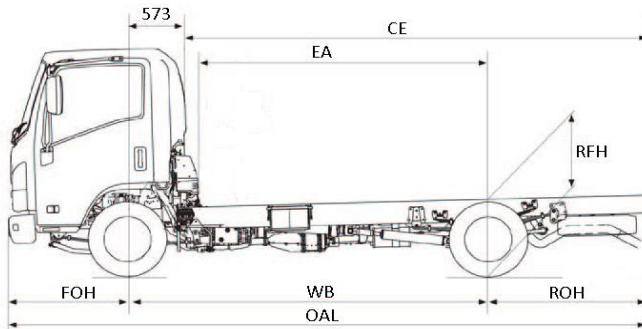

WARRANTY	